



300

915 Hybrid



KEY FEATURES

- Wide Cabin
- Dual SRS Airbags
- Easy Start – Take Off Assist
- Disc Brakes
 - Front & Rear
 - ABS, VSC & TRC – all STD
- Energy Absorbing Steering Wheel
- Driver's suspension seat
- 5-Speed Automated Manual Transmission (AMT)
- Emission Standard Euro 5

KEY SPECIFICATIONS

- GVM** 8500kg, optional 5995kg
- GCM** 12,000kg
- Engine** . . . 4.0-litre, Common Rail, Direct Injection
Turbocharged and Intercooled
- Power** 110kW (150Hp) @ 2500 RPM (ISO)
- Torque** 420Nm @ 1400 RPM (ISO)
- Wheelbase** 3870mm





915 Hybrid

XKU720R-HKUTSQ3 915 Hybrid

Engine, Driveline & Chassis specifications

ENGINE

Engine	Hino N04C UR
Max output (ISO Net)	110kW (150Hp) at 2500 RPM
Max torque (ISO Net)	420Nm at 1400 RPM
Maximum engine speed	3100 RPM
Type	Diesel, four cycle, four-cylinder in line, overhead valve, water cooled
Combustion system	Direct injection type
Bore & stroke	104 x 118mm
Piston displacement	4.009 litres
Fuel injection system	Electronic control, common rail type
Air intake system	Turbo inter-cooled, stack-type air intake
Air cleaner	Paper element
Fan clutch	Equipped
Exhaust system	Catalytic Converter with Diesel Particulate Active Reduction System (DPR)
Exhaust outlet	Horizontal
Emission control system	EGR & DPR meeting Euro 5 emission levels

HYBRID DRIVE SYSTEM

Motor Type	AC Synchronous motor
Rated voltage	300V
Max output	36kW
Max torque	333Nm
Idle stop	Equipped
Battery type	Nickel-metal hydride
Battery capacity	288V/6.5Ah

TRANSMISSION

Model	M550
Type	Five-speed overdrive AMT
Clutch type	Dry single plate, diaphragm type with damper springs
Facing outside diameter	300mm
Facing lining area	423 x 2cm ²
Control	Electronic with transmission

ELECTRICAL

Type	24 volt, negative earth
Batteries	12V x 2, series connected
Alternator type	Built-in rectifier and voltage regulator
Capacity	24V – 80 Amp
Starter Capacity	24V, 4.5kW

BRAKES

Service brakes	Hydraulic system with ventilated disc brakes front and rear
Control	Vacuum servo with hydraulic assist & dual circuits
Front disc diameter	287mm
Rear disc diameter	287mm
Anti-lock system (ABS)	Equipped
Vehicle Stability Control	Equipped
Traction Control	Equipped
Easy Start System	Equipped
Exhaust brake	Electric-vacuum actuator with valve in exhaust pipe
Park brake	Rear of transmission

PERFORMANCE & GEAR RATIOS

Engine RPM @ 100km/h	2600
Maximum speed (km/h)	120
Gradeability tan θ % @ GVM	31.2
Final drive ratio	5.142:1

M550

1st	4.981	5th	1.000
2nd	2.911	6th	0.738
3rd	1.556	Rev	4.625

AXLE LOAD & TYRE LOAD LIMITS

Front Axle	3100kg
Tyres	3100kg
Rear axle	6200kg
Tyres	6000kg
Front axle type	I Beam
Rear axle type	SH13 full-floating, single reduction, single speed by Hypoid gears

SUSPENSION

Front Suspension

Leaf	Semi-elliptic taper leaf springs with shock absorbers & stabiliser
Spring dimensions, span & width	1250mm x 70mm

Rear Suspension

Leaf	Semi-elliptic main and auxiliary tapered Leaf springs with silencers and shock absorbers
Spring dimensions, span & width	1310mm x 70mm
Auxiliary springs	900mm x 70mm

WHEEL & TYRES

Wheel type	6-stud disc wheel
Front wheel & rim size	225/80R17.5 123/122 x 17.5x6.0
Number of tyres	Seven including spare
Spare tyre carrier	Equipped



915 Hybrid

XKU720R-HKUTSQ3 915 Hybrid

Cab Equipment & Instrumentation

CHASSIS FRAME

Type	Ladder-shaped channel section side rails
Chassis width at rear	750mm
Max section (depth x flange x thickness)	192.8 x 65 x 5.9mm
Tensile strength	540N/mm ²
Towing hooks	Equipped at front and rear
Front bumper	Painted to cabin colour

CAB EXTERIOR

Type	Forward control, all steel welded construction, torsion-bar tilt mechanism, fully trimmed
Windscreen wipers	Electric, dual wipers, intermittent and 2-speed
Outside rear mirrors	Two, pillar mounted curved
Radiator grille	Painted same colour as cabin
Lamps	HID headlamps, fog lamps

CAB INTERIOR

Steering	Telescopic tilt column with integral power steering
Windscreen glass	Laminated glass
Seating capacity	Three
Driver's seat	4-way adjustable, urethane foam pads, high-back, lumbar support & suspension base
Assistant's seat	Fixed bench, urethane foam pads, high-back, lumbar support with suspension base
Seat cover	Fabric cover
Seat Belts	
Driver's seat	3-point type with ELR and pre-tensioner
Assistant's seat	3-point type with ELR and pre-tensioner
Centre passenger's seat	2-point type
Front Sun visors	For driver and passenger
Ventilator	Forced type by electric blower
Inside rear mirror	One, flat type
Cigarette lighter (24 volt)	Equipped
Audio	AM/FM radio with CD player
Heater and defroster	Equipped
Air conditioner	Equipped
Remote door locking	Equipped
Immobiliser	Equipped
Power Windows	Equipped
SRS airbag	Equipped for driver and left side passenger
Seat back console	Equipped (centre)
Overhead consoles	For driver and passenger
Cup holder	Equipped

POWER & TORQUE CHART (ISO NET) N04C UR

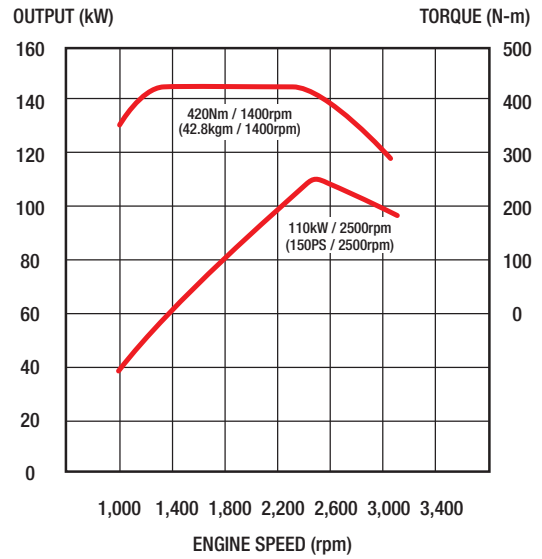

INSTRUMENTS

- | | |
|---|---|
| <p>1. Meters and gauges
 km-kg system
 Engine tachometer</p> <p>2. Warning, pilot lamps and buzzers
 Turning signal & hazard indicator lamp
 Exhaust brake indicator lamp
 Engine oil pressure warning lamp
 Battery charge warning lamp
 High beam indicator lamp
 Parking brake indicator lamp
 Engine malfunction indicator lamp
 Fuel level warning lamp
 Fuel filter water accumulating
 Level warning lamp
 Brake fluid level warning lamp
 Back-up warning buzzer
 Cab-tilt warning lamp
 ABS system failure warning lamp
 SRS airbag system failure warning lamp
 Easy Start indicator lamp</p> <p>3. Switches
 Lighting switch
 Wiper and washer switch
 Exhaust brake switch
 Easy Start switch
 Easy Start release timing adjuster switch
 Traction Control OFF</p> | <p>4. Multi Information Display
 Fuel gauge
 Coolant temperature gauge
 DPR accumulation gauge
 Odometer
 2 trip meters
 Fuel consumption
 - Current
 - Average</p> <p>5. Others
 One-key starting-stopping
 Horn button
 Remote door locking</p> |
|---|---|

STEERING

Type	Telescopic and tilt steering column with locking device. Rack & pinion with integral power steering
Steering angle	Inside: 44° Outside: 34°



300

915 Hybrid Dimensions

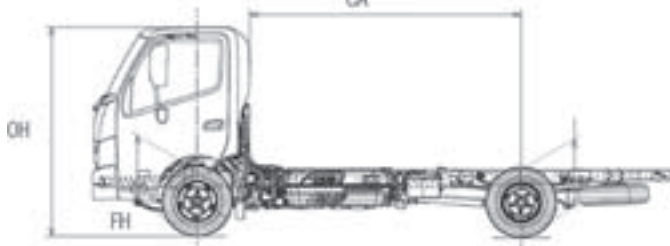
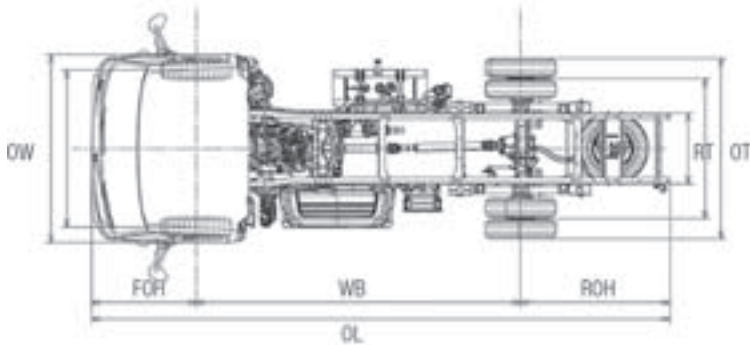

DIMENSIONS - mm / Capacities

Model	915 Hybrid
Product Code	XKU720R-HKUTSQ3
Wheelbase (WB)	3870
Overall tyre width (OT)	2060
Overall length (OL)	6735
Overall width (OW)	1995
Overall height (OH)	2235
Front track	1655
Rear track	1590
Cab to axle centre (CA)	3310
Front overhang (FOH)	1110
Rear overhang (ROH)	1760
Front chassis height	725
Rear chassis height	815
Road clearance	200
Turning circle – m (kerb-to-kerb)	13.8
Turning circle – m (wall-to-wall)	15.2
Fuel tank – lt	100
Indicative chassis mass – kg (standard tools, 10 litres of fuel, without spare tyre)	
Total	2630
Front	1735
Rear	895
GVM Rating*	8500
GCM Rating	12000
*Std GVM = 8500 OPT 5995	

WARRANTIES

New vehicle warranty period

Light Duty Model	Axle Configuration	Standard Warranty	Cab corrosion perforation
915 Hybrid	4 x 2	3 years or 100,000km	36 months

For detailed warranty conditions, please refer to Hino Truck Warranty brochure.

DISCLAIMER

Important notice. Hino Trucks are distributed in New Zealand by Hino Distributors (NZ) Ltd.

All effort has been made to ensure the information contained in this brochure was correct at time of printing. Hino Distributors (NZ) Ltd reserves the right to alter any details of the specifications & equipment without notice. Hino in so far as it is permitted by law to do so, shall not be liable in any way as a result of any reliance placed by any person on anything contained in this brochure. You should therefore check with your authorised Hino dealer at the time of ordering your motor vehicle to ensure that colour, specifications, equipment, design features & options are available for the vehicle you are ordering. Please note that some options may only be available in combination with others. Authorised Hino dealers will on request provide up to date information on all accessories, design features, prices & availability.