

300 Series MY20 Cab & Chassis Drawings

Model	815 / 915 / 917 WIDE CAB	
Variant	Product Code	Chassis Drawing
815 AT 3430 WIDE	XZU710R-WKTRSQ3	CH-4
915 AT 3430 WIDE	XZU710R-WKTSSQ3	CH-4
917 MT 3430 WIDE	XZU710R-WKFTTQ3	CH-4
917 MT 3870 WIDE	XZU720R-WKFTTQ3	CH-5
917 MT 4200 WIDE	XZU730R-WKFTTQ3	CH-8

No. CH-4

Unit : mm

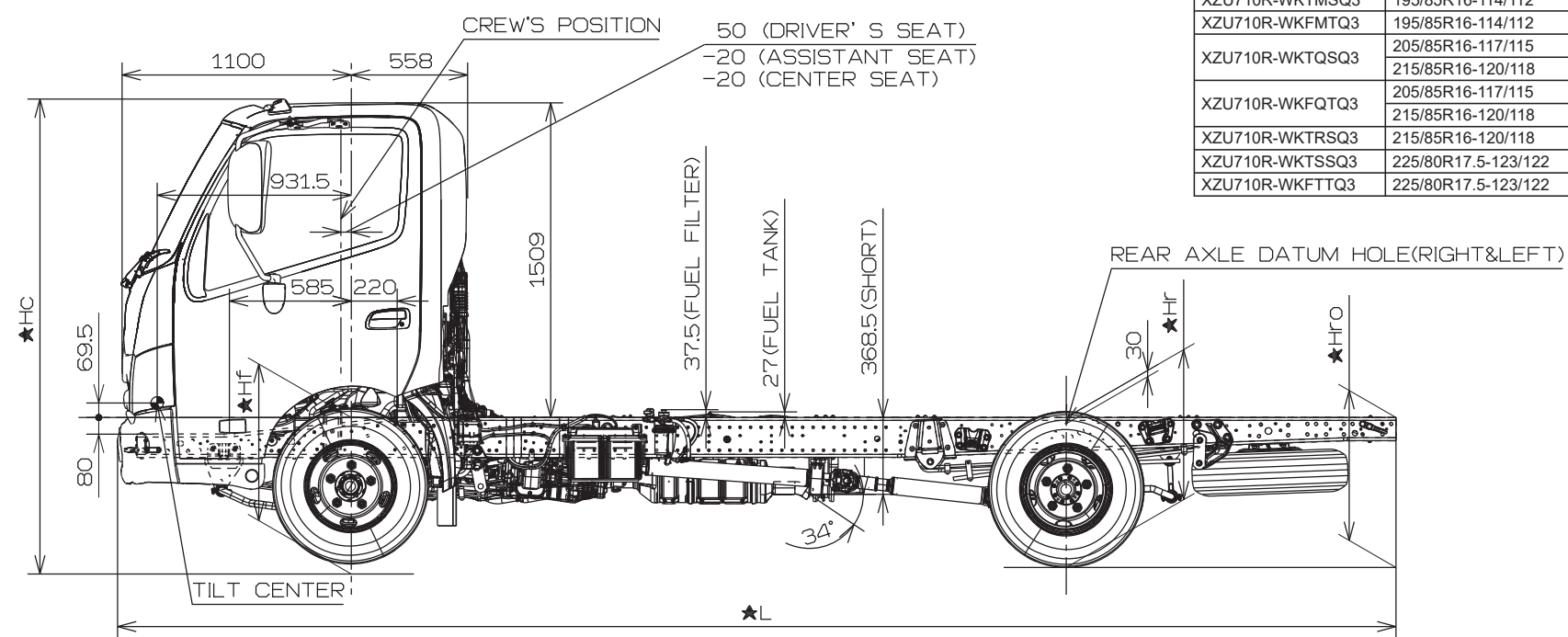
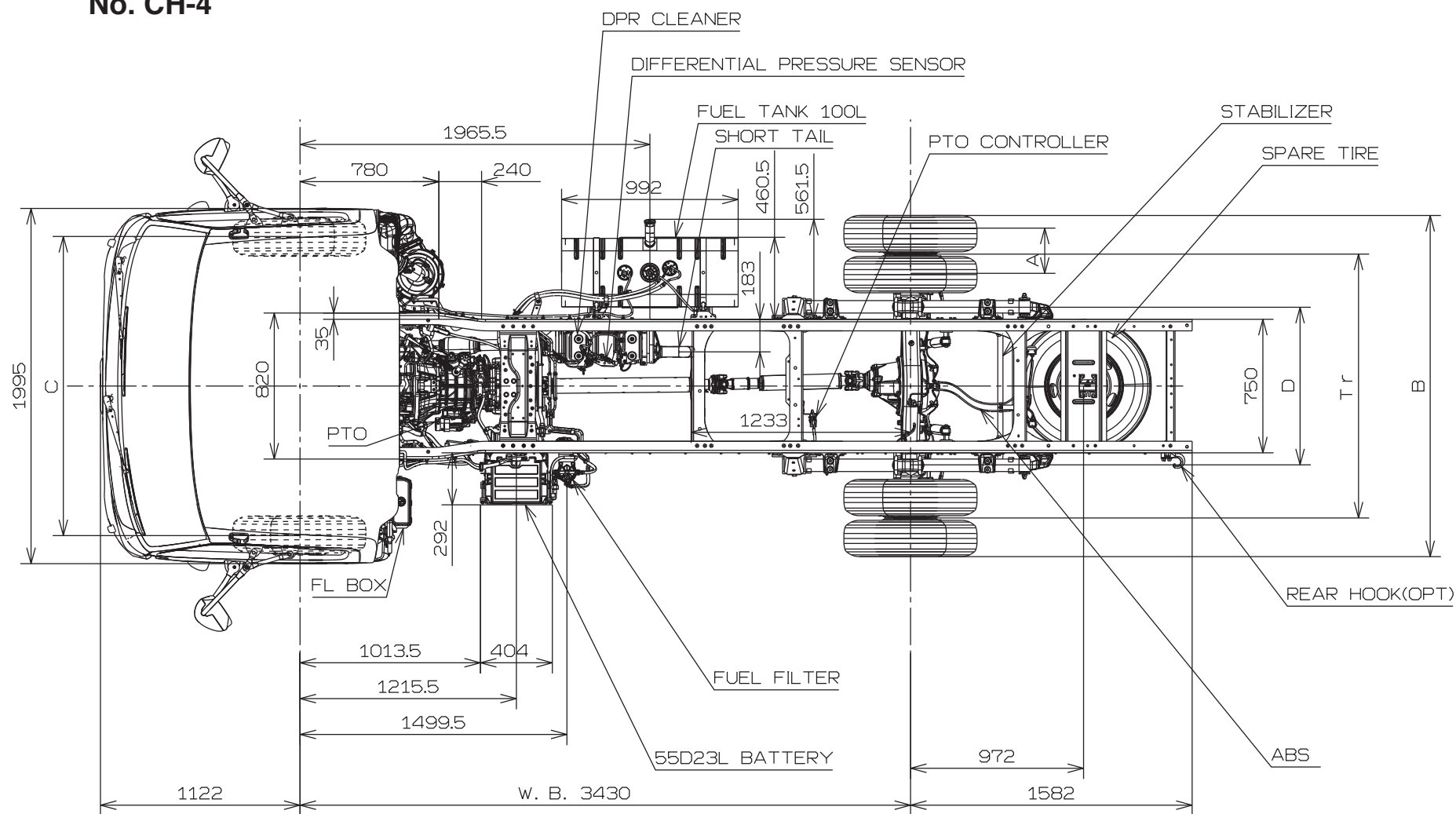

MODEL	TIRE SIZE	A	B	C	D	Tr	DETAIL OF ★L				★L	★Hc		★Hf	★Hr	★Hro
							FRAME	HOOK	SPARE TIRE	Rr. BUMPER		ROOF	LAMP			
XZU710R-WKMTSQ3	195/85R16-114/112	226	1904	1665	890	1480	6122	6080	-	-	6122	2191	2206	681	750	782
XZU710R-WKFMTQ3	195/85R16-114/112	226	1904	1665	890	1480	6122	6080	-	-	6122	2192	2207	682	750	782
XZU710R-WKTSQ3	205/85R16-117/115	244	1969	1665	890	1520	6122	6080	-	-	6122	2209	2225	700	759	786
	215/85R16-120/118	244	1977	1665	890	1520	6122	6080	-	-	6122	2220	2235	710	768	795
XZU710R-WKFQTQ3	205/85R16-117/115	244	1969	1665	890	1520	6122	6080	-	-	6122	2210	2226	701	759	786
	215/85R16-120/118	244	1977	1665	890	1520	6122	6080	-	-	6122	2220	2236	711	769	795
XZU710R-WKTRSQ3	215/85R16-120/118	244	1977	1665	890	1520	6121	6079	-	-	6121	2223	2236	713	795	833
XZU710R-WKTSSQ3	225/80R17.5-123/122	254	2063	1655	890	1590	6121	6079	-	-	6121	2240	2253	730	810	848
XZU710R-WKFTTQ3	225/80R17.5-123/122	254	2063	1655	890	1590	6121	6079	-	-	6121	2241	2253	731	815	854

[NOTE]

- The dimensions described above are designed figure under the chassis condition.
- When selected or fitted optional equipment or local parts such as tire, leaf spring, fuel tank and etc., should be examined the frame height from ground by body manufacturer.
- Figures marked "★" dimensions are measured in parallel with the surface of the ground.
- In case of T/M A860E, see the CAB BACK drawing.

No. CH-5

Unit : mm

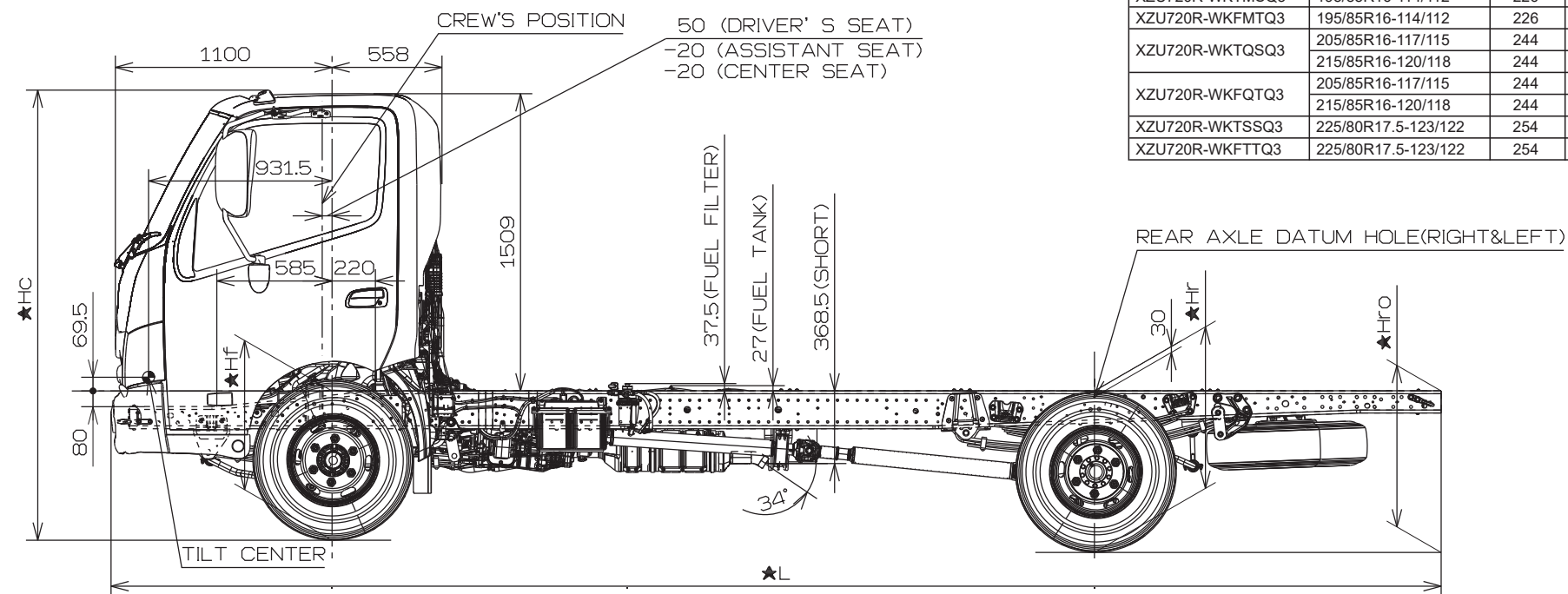
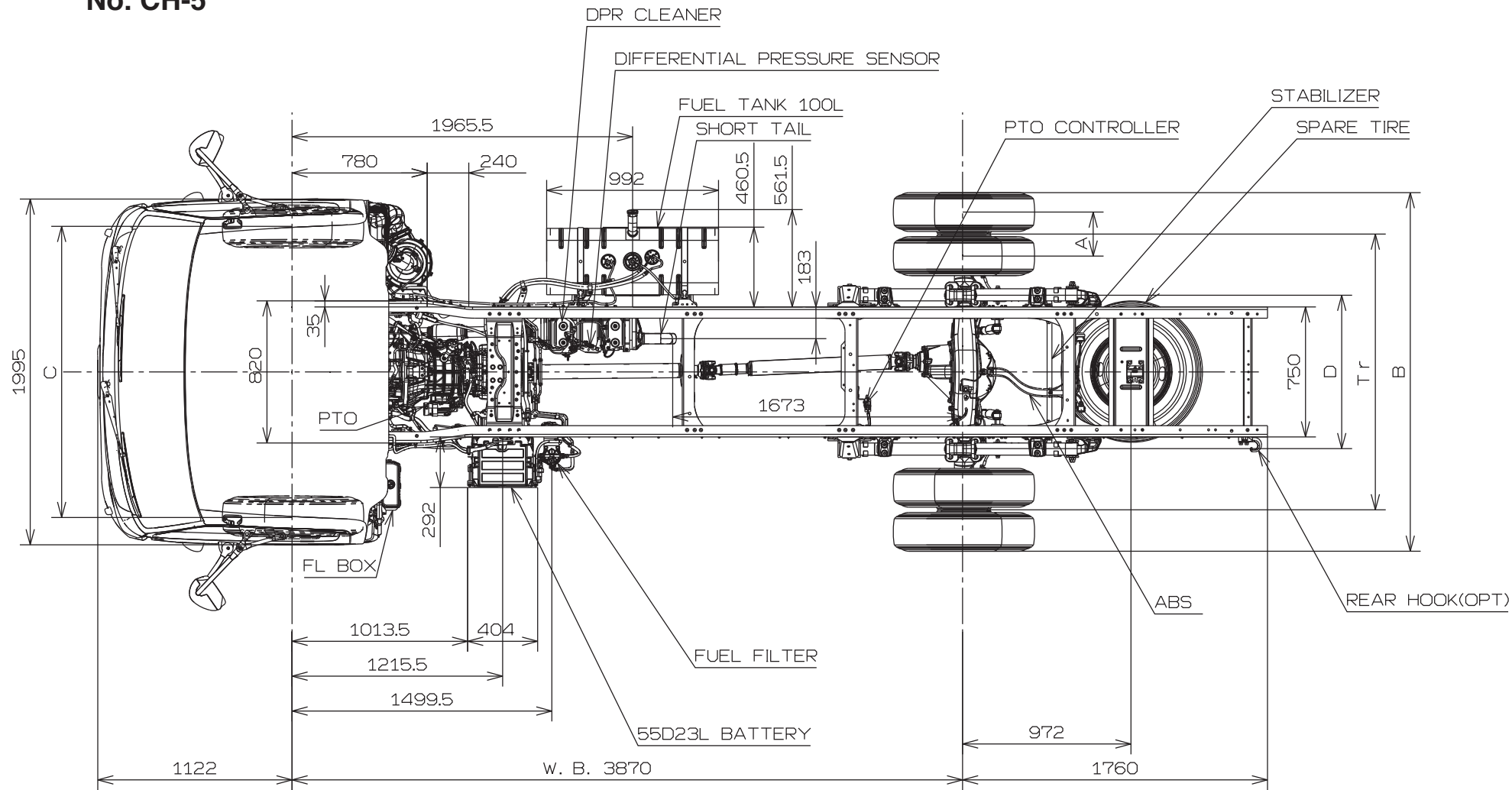

MODEL	TIRE SIZE	A	B	C	D	Tr	DETAIL OF ★L				★L	★Hc		★Hf	★Hr	★Hro
							FRAME	HOOK	SPARE TIRE	Rr. BUMPER		ROOF	LAMP			
XZU720R-WKTMSQ3	195/85R16-114/112	226	1904	1665	890	1480	6740	6705	-	-	6740	2190	2205	680	750	782
XZU720R-WKFMTQ3	195/85R16-114/112	226	1904	1665	890	1480	6740	6705	-	-	6740	2191	2206	681	751	782
XZU720R-WKTQSQ3	205/85R16-117/115	244	1969	1665	890	1520	6740	6705	-	-	6740	2209	2225	699	759	786
	215/85R16-120/118	244	1977	1665	890	1520	6740	6705	-	-	6740	2219	2235	709	768	795
XZU720R-WKFQTQ3	205/85R16-117/115	244	1969	1665	890	1520	6740	6705	-	-	6740	2210	2226	700	759	786
	215/85R16-120/118	244	1977	1665	890	1520	6740	6705	-	-	6740	2220	2236	710	769	795
XZU720R-WKTSSQ3	225/80R17.5-123/122	254	2063	1655	890	1590	6739	6704	-	-	6739	2239	2253	729	811	848
XZU720R-WKFTTQ3	225/80R17.5-123/122	254	2063	1655	890	1590	6739	6704	-	-	6739	2240	2254	730	815	854

[NOTE]

- The dimensions described above are designed figure under the chassis condition.
- When selected or fitted optional equipment or local parts such as tire, leaf spring, fuel tank and etc., should be examined the frame height from ground by body manufacturer.
- Figures marked "★" dimensions are measured in parallel with the surface of the ground.
- In case of T/M A860E, see the CAB BACK drawing.

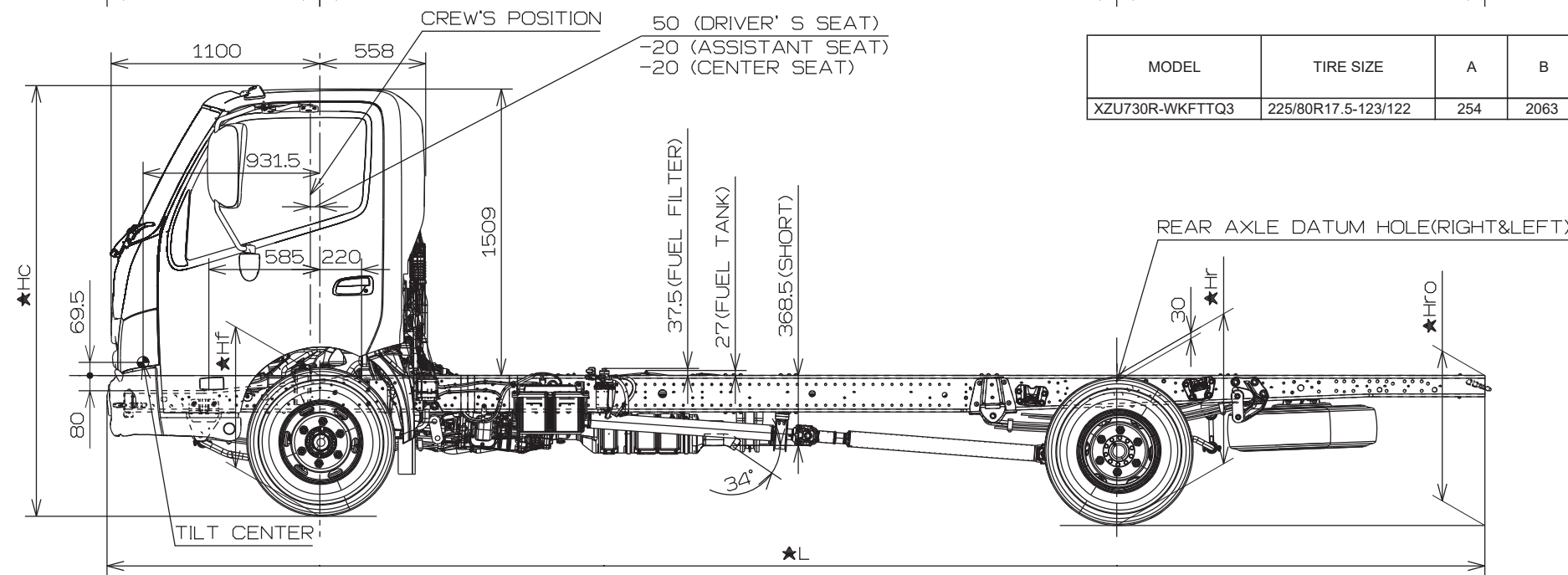
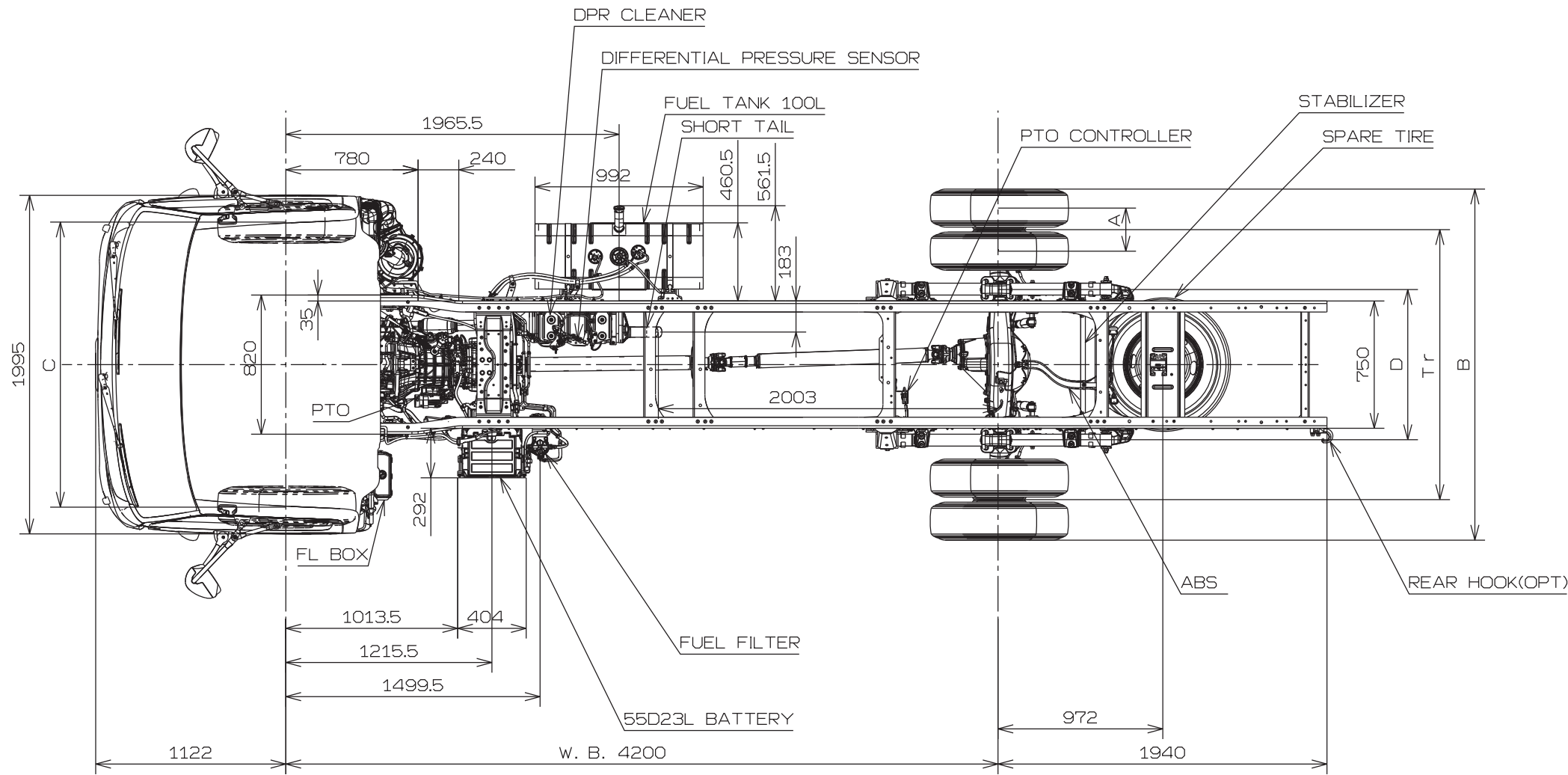

MODEL	TIRE SIZE	A	B	C	D	Tr	DETAIL OF ★L				★L	★Hc		★Hf	★Hr	★Hro
							FRAME	HOOK	SPARE TIRE	Rr. BUMPER		ROOF	LAMP			
XZU730R-WKFTTQ3	225/80R17.5-123/122	254	2063	1655	890	1590	7249	7283	-	-	7283	2239	2254	730	815	854

[NOTE]

- The dimensions described above are designed figure under the chassis condition.
- When selected or fitted optional equipment or local parts such as tire, leaf spring, fuel tank and etc., should be examined the frame height from ground by body manufacturer.
- Figures marked "★" dimensions are measured in parallel with the surface of the ground.